

**NOTES:**

- 1.) Post size depends on fence height and wind loads. See *MONTAGE™* specifications for post sizing chart.
- 2.) Third rail required for *Double Rings*.
- 3.) Available in 3" air space and/or Flush Bottom on most heights.
- 4.) Three rails required for 6' tall.

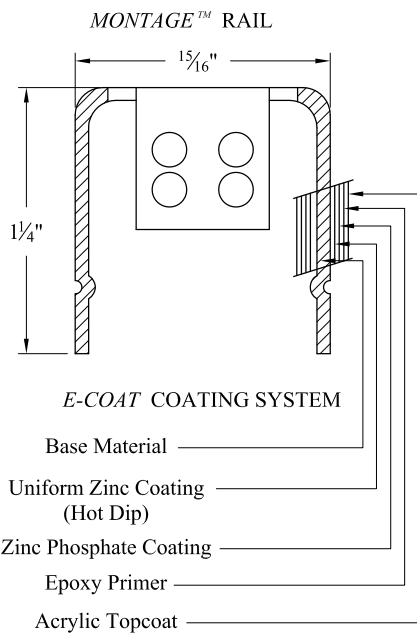

**RAKING DIRECTIONAL ARROW**  
Welded panel can be raked 45" over 8' with arrow pointing down grade.

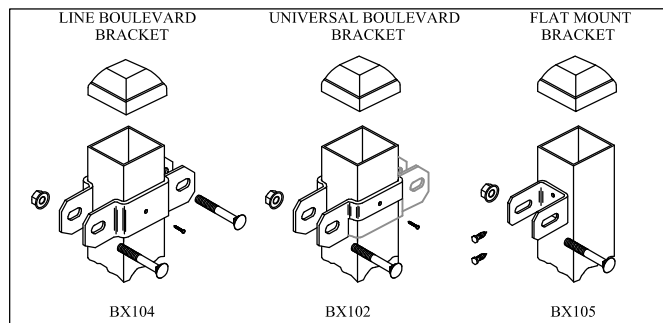
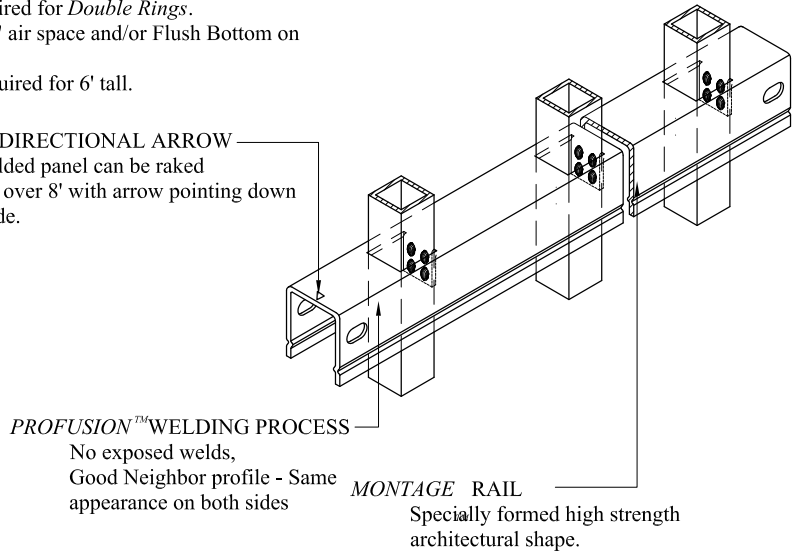

**RESIDENTIAL WELDED STEEL PANEL**  
**PRE-ASSEMBLED**

Values shown are nominal and not to be used for installation purposes. See product specification for installation requirements.

RCISO

Title: <b>MONTAGE CLASSIC 2/3-RAIL</b>		
DR: CI	SH . 1 of 1	SCALE: DO NOT SCALE
CK: ME	Date 7-19-11	REV: c

Ameristar Montage Classic Fence  
Distributed by:  
Ornamental Fence Supply, LLC  
Big Rock, IL Phone: 800-448-1293 [www.ornamentalfencesupply.com](http://www.ornamentalfencesupply.com)